

The "All-Toob"

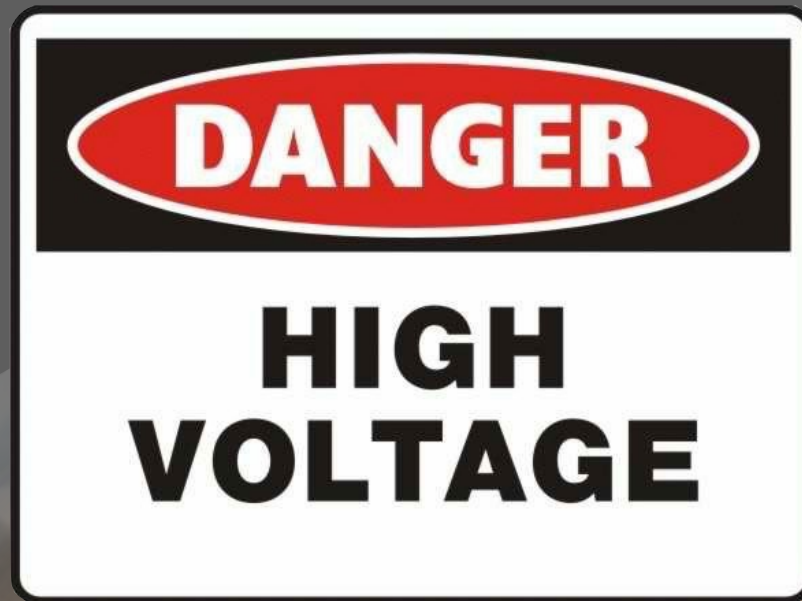

A Dekatron Spinner Kit Designed
by SGITHEACH

An Important Note On Safety



Caution! Like most equipment that uses vacuum valves/tubes, the All-Toob¹ Dekatron spinner uses high voltages in order to operate. You need to respect this and other hazards inherent in these circuits.

Caution! The All-Toob spinner must only be operated with the case securely in place around the electronics. Keep the internals away from prying hands and stray pets!

Caution! This device uses mains/line supply with no isolation and cannot be earthed/grounded. Special care must be taken if the device is powered when not in an enclosure.

Caution! This device uses high voltages in the region of 450V DC during operation!

Caution! If a metal enclosure is used as a case, then the device must be fully isolated from it and the enclosure itself must be earthed/grounded.

Caution! Do not touch the electronics while the All-Toob is in use or has been recently operated. Treat this device with the same level of common sense as any mains-powered electrical item – do not expose to wet environments, keep out of the reach of children, animals etc. Do not eat!

Caution! Some components may be warm to the touch during use.² This is a perfectly normal consequence of their operation, but you should remember it when handling the board or considering alternative enclosures.

Legal Statement

The All-Toob Dekatron Spinner is built and documented with an Open Source³ philosophy in mind. All the source files including circuit diagrams, Eagle board and case design files are provided under a Creative Commons ShareAlike 4.0 International license.

More specifically:

- You may share, copy and redistribute the material in any medium or format.
- You may remix, transform and build upon the material presented herein.
- You **MUST** give appropriate credit, provide a link to the license and *indicate if changes have been made*.
- This license is for **NON-COMMERCIAL** use only, you may not use the material for commercial gain.
- If you remix, transform, 'improve', modify or build upon the material presented herein, you must distribute your contributions under the same license as the original.

¹ Get it? ;-)

² Why are you touching them!!

³ https://en.wikipedia.org/wiki/Open-source_hardware

- You may not apply legal terms or technological measures that legally restrict others from doing anything the license permits.
- For further information, please see the following URL: <http://creativecommons.org/licenses/bync-sa/4.0/> or send a letter to Creative Commons, PO Box 1866, Mountain View, CA 94042, USA.

In addition you should note the following (in the event that there is any conflict between these notes and the License given above, then the License shall take priority).

The All-Toob Dekatron Spinner may be hazardous if not assembled and operated by suitably knowledgeable and practised persons or if abused. It is your responsibility to carefully review the documentation, the design and the kit contents and to assure yourself that you have the necessary expertise to construct and/or operate the spinner safely. In particular, it is also your responsibility to ensure that the completed All-Toob Dekatron Spinner meets any necessary safety and other regulations or guidelines for such items in your jurisdiction. It is possible that in some jurisdictions, a completely different type or construction of enclosure may be required to obtain regulatory compliance. Assembly instructions in the kit documentation are intended as a starting point, to be amended or not according to the judgement and expertise of a suitably qualified constructor.

The hazards of this kit include, but are not limited to, high voltages, the generation of heat during operation, the presence of toxic substances within the components of the kit and the presence of sharp and/or fragile glass and metal items. Not all components within this kit comply with the Restriction of Hazardous Substances regulations (RoHS), though compliant components have been selected in most cases.

In summary, you own, construct and use the All-Toob Dekatron Spinner entirely at your own risk. To the maximum extent permitted by law, we disclaim all liability for any and all adverse outcomes associated with your ownership, construction and use of this item.

Warranty Information

Upon receipt of the kit of parts, any missing or broken pieces will be replaced. It is incumbent upon the recipient to check the contents in a prompt manner against the supplied parts lists found within this manual. As a kit of parts, no warranty can be provided pertaining to the quality of construction and operation of the final product as this is the duty of the purchaser and is dependent upon their skill. The spinner may be hazardous if not assembled and operated by suitably knowledgeable persons and it is the owners responsibility to carefully review all the supplied documentation. The authors have made their best attempts to explain and detail the construction and hazards associated with operation of the tester within this manual. Within the All-Toob Dekatron Spinner certain hazards are present, namely high voltages and due care and attention should be paid when handling said items. If you have purchased a complete operational All-Toob Dekatron Spinner then a limited warranty is provided in a separate document supplied with your device. If the kit or complete spinner has arrived in a damaged state such that an insurance claim is likely to be made, then please notify us immediately (within a few days of receipt). It is likely that photographic evidence will be asked for to make the insurance claim.

No refunds on partially or fully constructed kits are possible.

Right. Now on to the fun part.....

The All-Toob Dekatron Spinner - An Introduction

What is a Dekatron you may be asking yourself? Well, back in the good ole infancy of computing, counting (and displaying!) numbers wasn't as straightforward as it is today.⁴ Numerous technologies burgeoned through the 1950's and '60's to aid in counting numbers and processing calculations. One of these technologies was the Dekatron, or glow-transfer counting tube.⁵ The name Dekatron was a brand name used by Ericsson Telephones Limited (ETL) of Beeston in Nottingham (UK). These functioned as both counting devices and displays and came in a variety of configurations.⁶ These included counting in base 5, 10 and 12, register tubes as well as selector varieties that made dividing by n possible and hence usage in calculators and early computers. The Dekatron tube comprises a central anode encircled by a set of cathodes whereby a correct sequence of pulses can propel (or transfer) a neon (or other gas discharge) from one cathode to the next. They typically operated at pretty high voltages in the range of 450V DC. Depending on the type of gases used in the tube counting frequencies from several Hz to 1MHz were possible. Probably one of the most 'famous' examples of the use of these devices in computing was the Harwell computer.⁷

The All-Toob Dekatron Spinner allows you to enjoy a little piece of computing history in all its warm neon glory. In homage to the days of old the spinner uses vacuum tubes as rectifiers and also a neon trigger tube (Z700U) to stay as true to the technology of the day as is feasible with cost constraints in mind! In fact this design could have been built in the 1950's as all the electronic components would have been available. This has been married to some more modern case components as the laser cut acrylic and 3D printed mounts in the case are very much of this decade. We hope you enjoy the culmination of this effort.

⁴ What with new-fangled things like LED displays and such....

⁵ Others include Beam switching tubes, Nomotrons.....

⁶ For a more humorous (and animated) description of the operation of a Dekatron see <https://threeneurons.wordpress.com/dekatron-stuff/> or <http://www.electricstuff.co.uk/dekatron.html>

⁷ https://en.wikipedia.org/wiki/Harwell_computer

Building the board

If you are an experienced constructor then you'll probably only need a quick look through these notes before continuing. The components to fit all depend on what type of Dekatron you plan on using. There are two distinct types that the All-Toob will drive with aplomb, single pulse and double pulse types.

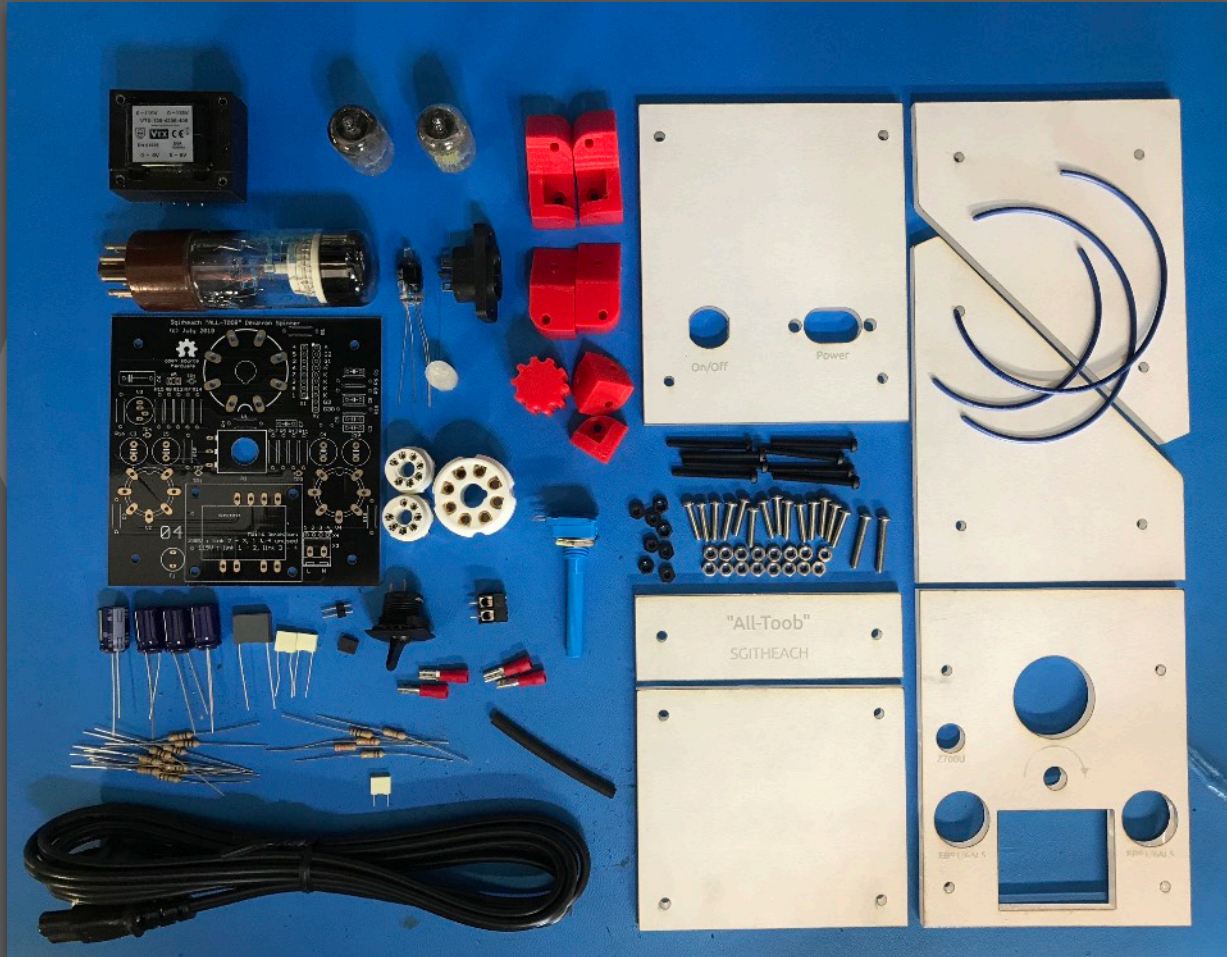

The Kit Contents - For a Double Pulse Dekatron (GC10B shown here) - 3D Printed Parts in Red for clarity

These are as follows:

Single Pulse: GC10D, CV5143

Double Pulse:⁸ GC10B, GC10B/S, GC10B/L, GC10/4B, GC10/4B/L, GC12/4B, CV1739, CV2271, CV2321, CV6044, CV6100, Z302C, Z303C, VX9194, VX9194/4B, M2465-401C.

The first following table details the parts fitted to the board *no matter which type of Dekatron you intend to use*. The specific components required for each type then follow in the two subsequent tables. It is suggested that you start with the smallest components first (links, resistors and capacitors) and finish with the largest ones (potentiometer, valve bases, transformer and finally the 3 socketed valves). The following check lists can be used, if so desired, by ticking off each component as it is fitted. When mounting the transformer use the supplied nylon bolts before soldering the transformer to ensure it is aligned correctly.

⁸ /S means British Services i.e. mil spec. /L means long life

Tick	Part No.	Value	Notes
<input type="checkbox"/>	X1 to X2 links	Depends on Dekatron in use see separate diagrams	See Page 9
<input type="checkbox"/>	X3	Screw terminal	All
<input type="checkbox"/>	X4 links	Select mains/line voltage	Instructions are on the PCB
<input type="checkbox"/>	X5	2 pin header and jumper	
<input type="checkbox"/>	C2	6n8 400V	
<input type="checkbox"/>	C3, C4, C5, C10	4u7 400V	
<input type="checkbox"/>	C6	100n 400V	
<input type="checkbox"/>	C7	4n7 400V	
<input type="checkbox"/>	R2	1k5	
<input type="checkbox"/>	R3	1M potentiometer	See picture on page 7
<input type="checkbox"/>	R4	680k	
<input type="checkbox"/>	R5, R8	1M	
<input type="checkbox"/>	R7, R16	10M	
<input type="checkbox"/>	R10, R13	47k	
<input type="checkbox"/>	R14	1M2	
<input type="checkbox"/>	R15	150R	
<input type="checkbox"/>	R19	3k3	
<input type="checkbox"/>	V3	Z700U	Use the 3D printed stand-off
<input type="checkbox"/>	V2, V4	B7G PCB valve socket	
<input type="checkbox"/>	V1	Octal valve socket	
<input type="checkbox"/>	TR1	Dual 115V primaries Dual 6V secondaries	Looks better (IMHO) with the label peeled off
<input type="checkbox"/>		4 off M3 30mm nylon bolt & nut	To mount TR1
<input type="checkbox"/>	V2, V4	EB91/6AL5	
<input type="checkbox"/>	V1	your Dekatron	

For Single Pulse Dekatrons install the following:

Tick	Part No.	Value	Notes
<input type="checkbox"/>	C1, C9	100p 100V	
<input type="checkbox"/>	R1	330k	
<input type="checkbox"/>	R6	220k	

<input type="checkbox"/>	R9	link	
<input type="checkbox"/>	R12	1M	
<input type="checkbox"/>	R18	220k	
<input type="checkbox"/>	R17	330k	

For Double Pulse Dekatrons install the following:

Tick	Part No.	Value	Notes
<input type="checkbox"/>	C8	1n 100V	
<input type="checkbox"/>	R1	1M	
<input type="checkbox"/>	R6	33k	
<input type="checkbox"/>	R9	82k	
<input type="checkbox"/>	R11	47k	
<input type="checkbox"/>	R17	150k	

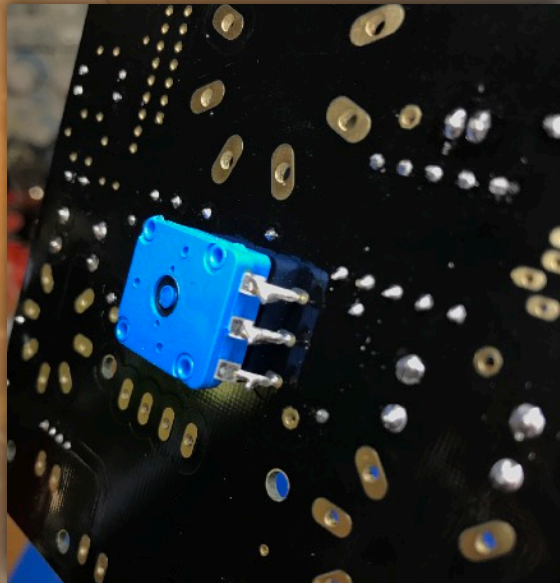

Photos: **Above Left:** All resistors in place for a Double Pulse Dekatron, resistor lead off cuts used to make the appropriate voltage selection for the mains input (110V shown): **Above Right:** When soldering the potentiometer, bend the leads down towards the PCB and use some resistor off cuts to bridge the gap to the pads on the board. **If you use your own potentiometer when constructing a kit it must have a plastic or similar non conducting shaft!** **Left:** The completed board - Note that the Z700U trigger tube is mounted on a 3D printed spacer. Attach the transformer with the 4 M30 nylon nuts and bolts *before* soldering for best results. Take care to solder the tube sockets so they are level with the board. Note - socket pins are shown here for the Dekatron selection jumpers, but usually you'd solder links in for the appropriate tube.

Initial testing

If you wish you can now connect up the board to a 115V or 230V AC supply (as appropriate) and the board should function (it takes a few seconds for the heaters to warm up on the rectifiers, be patient...!). Adjusting the potentiometer should vary the spin speed. Fitting or removing jumper X5 (when the board is not powered) should have a coarse affect on the dekatron spin speed.

Safety

You should only carry out these tests with the board powered by an isolating transformer and the GND connection on the board connected to ground/earth. Even so, do not forget there is nearly 500V DC on the board.

When you switch off the board please allow several minutes for the capacitors to discharge.



Which Dekatron?

Dekatron Connections

The All-Toob can use a variety of Dekatrons. X1 and X2 allow Dekatrons with different pinouts to be connected and the arrangement of X1 and X2 makes it very simple to use straight links for GC10B, GC10/4B and GC12/4B Dekatrons and their variants. Other Dekatrons such as the GC10D require crossing links or equivalents.

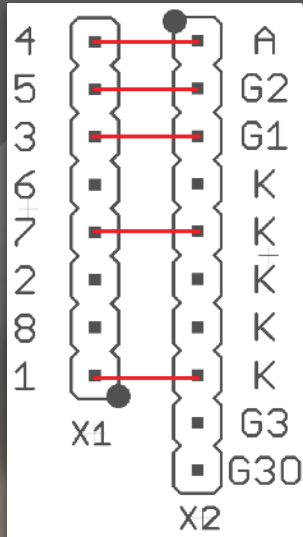

GC10B
(including variants and CV equivalents)

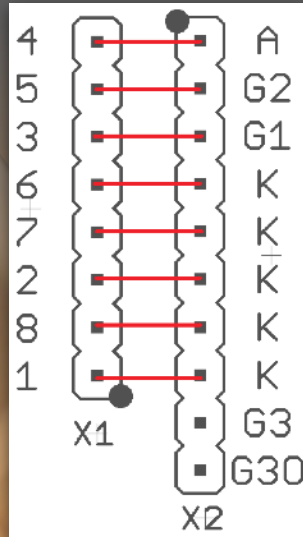

GC10/4B and GC12/4B
(and CV equivalents)

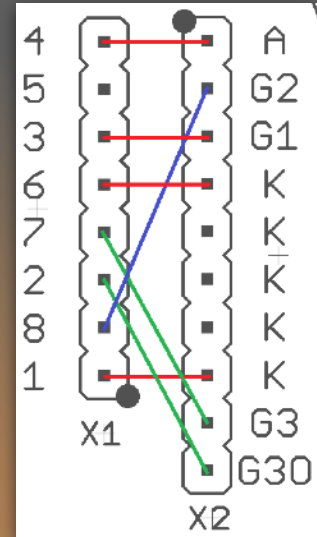

GC10D
(and CV equivalents, colour used for clarity)

Pin	GC10B (note 1)	GC10/4B (note 2)	GC10D
1	K1-9	K1-9	K1-9
2	n.c.	KD	G3
3	G1	G1	G1
4	a	a	a
5	G2	G2	n.c.
6	n.c.	KA	K0
7	K0	KB	G3Out
8	n.c.	KC	G2

Notes:

1. Includes GC10B/S, GC10B/L
2. Includes GC10/4B/L, GC12/4B
3. a = Anode
4. G₁ = 1st Guide
5. G₂ = 2nd Guide
6. G₃ = 3rd Guide
7. G₃₀ = Output 3rd Guide
8. K_A = Main cathode A
9. K_B = Main cathode B
10. K_C = Main cathode C
11. K_D = Main cathode D
12. K₀ = Main cathode 0
13. K₁₋₉ = Remaining cathodes

Case Building

Now you have a functioning spinner, it needs a nice home⁹. Here's a monochrome view of the assembled case with the bare PCB in it. The following link will take you to a full-featured 3D view that can be manipulated to gain insight into how the case is constructed...<https://a360.co/2OKzhG6>

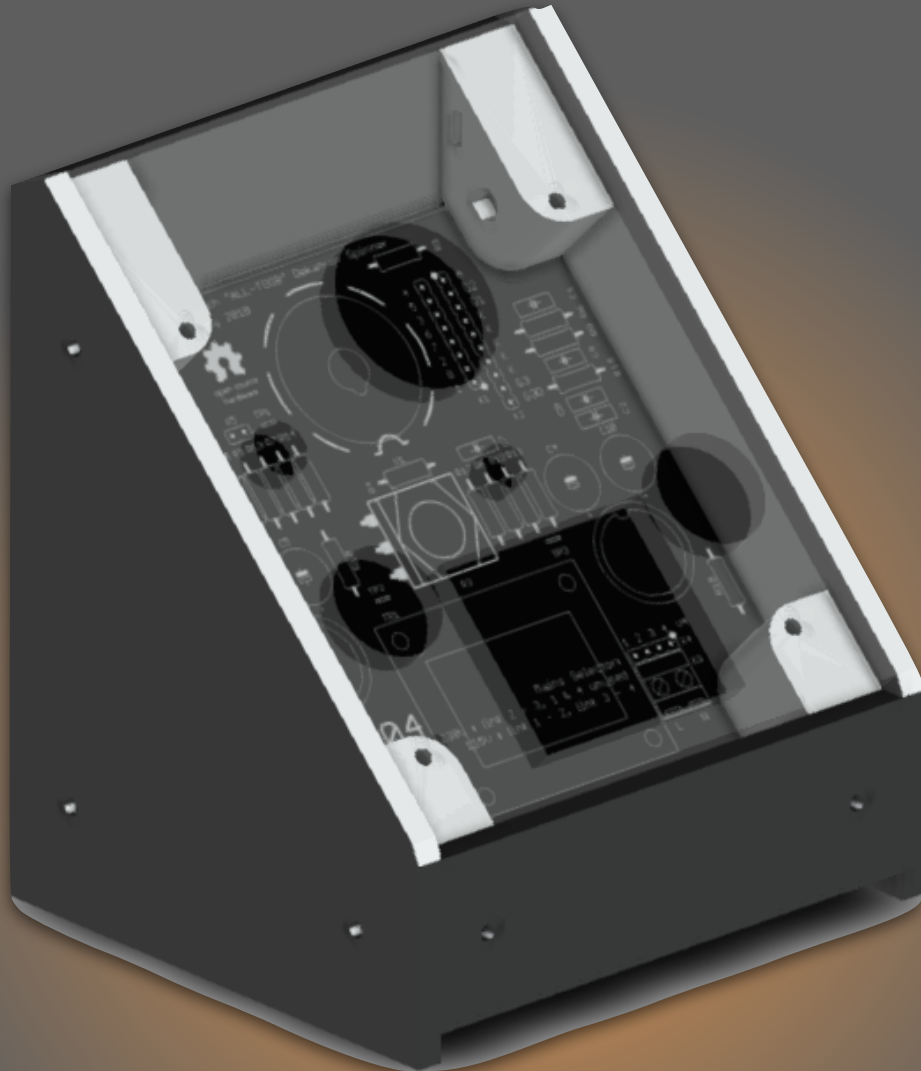

Tools Required

The following tools are essential to build the case:

- Small and medium flat blade screw drivers
- Medium cross-head screw driver
- Small adjustable spanner (wrench)
- 2mm hex key (Allen key or Allen wrench)
- Slip joint pliers (channel-locks) or similar (see text)
- Wire cutters
- Wire strippers
- Soldering iron, solder

A hot air gun is useful for heating shrink wrap insulation, but not absolutely necessary.

⁹ Unless of course you purchased a complete ready built All-Tool!

Parts List

Where an item is shown in brackets, such as (15mm), it is a supplied alternative when using 6.35mm thick (USA) acrylic instead of 5mm thick acrylic (Europe).¹⁰

Tick	Parts	Notes
<input type="checkbox"/>	6 off acrylic panels	Laser cut acrylic - see below
<input type="checkbox"/>	6 off corner connectors	3D printed - see below
<input type="checkbox"/>	Potentiometer knob	3D printed
<input type="checkbox"/>	Square M3 nut, 6mm grub-screw	To mount knob
<input type="checkbox"/>	"Figure of 8" mains inlet	
<input type="checkbox"/>	"Figure of 8" mains cable	USA, northern Europe or UK only
<input type="checkbox"/>	2 off each, M3, 12mm (15mm) bolt, washer and nut	To mount mains inlet
<input type="checkbox"/>	Mains switch	
<input type="checkbox"/>	4 off, M3, black nylon 30mm bolt and nut	To mount together PCB, acrylic face panel and 3D printed parts
<input type="checkbox"/>	14 off M3 nuts	Push fit into the 3D printed parts
<input type="checkbox"/>	2 off M3 square nuts	Slide into slots on 3D printed parts
<input type="checkbox"/>	14 off M3 12mm (15mm) bolt	Assemble panels onto 3D printed parts
<input type="checkbox"/>	2 off M3 20mm (25mm) bolt	Assemble panels onto 3D printed parts
<input type="checkbox"/>	Pre-crimped wire connections	To connect mains inlet, switch and to the screw terminals on the PCB
<input type="checkbox"/>	50mm heat shrink tube	To cover mains inlet and switch connections

Acrylic Panels¹¹

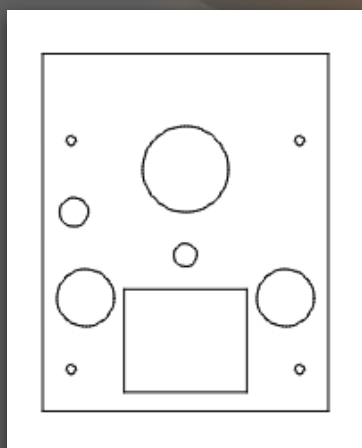

Clear Face Panel

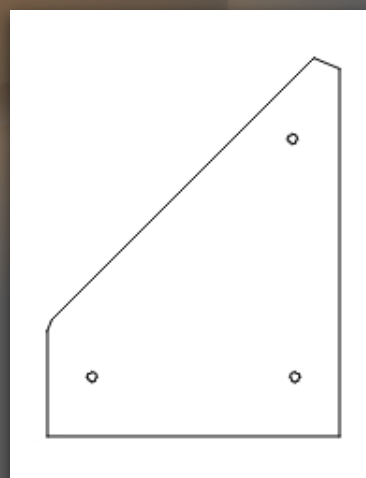
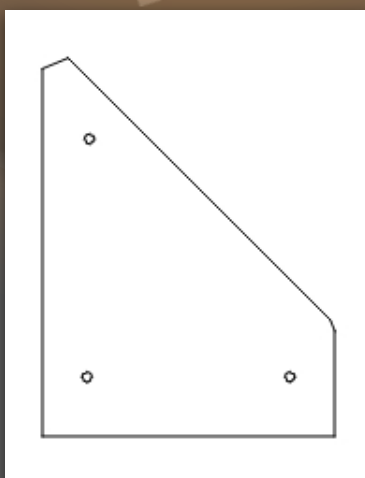

Orange Side Panels (Left and Right)

¹⁰ Because it appears to be *very difficult* to obtain 5mm acrylic on the west side of the Atlantic!! Good grief...when will we all come to a measurement consensus and go metric!! <end rant>

¹¹ These are supplied in the kit in some *interesting* colours.....all the plans are open source, so if you're building your own feel free to make your own colour statement!



Orange Front Panel

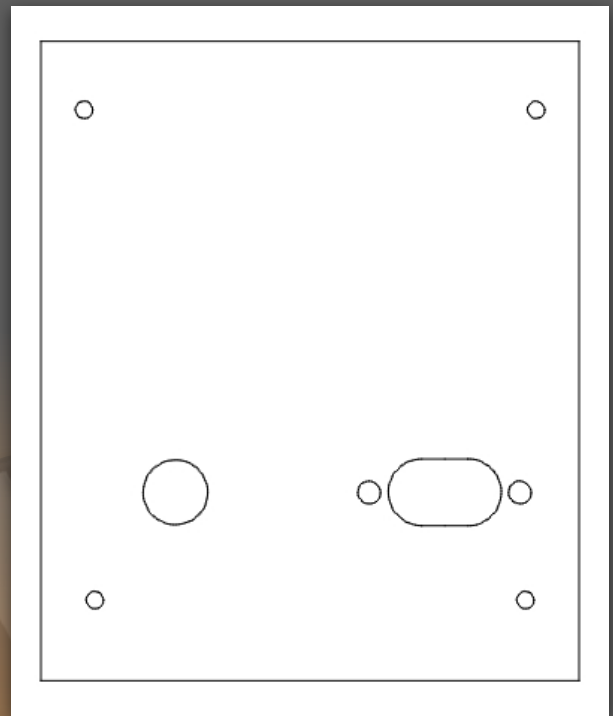

Orange Back Panel

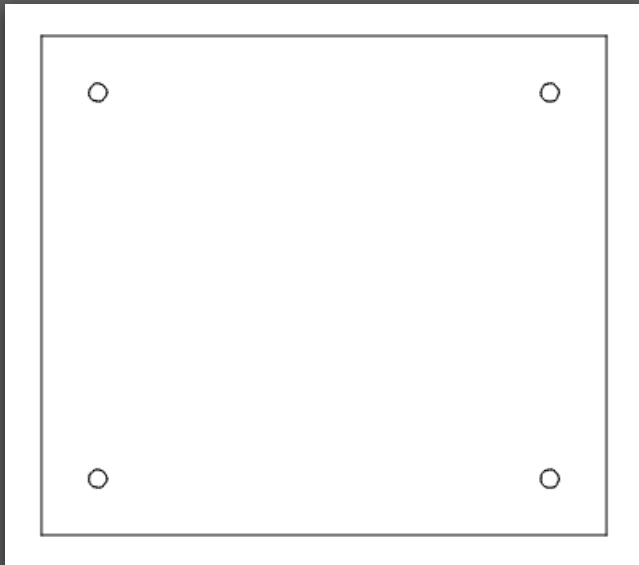

Clear Under Panel

3D Printed Parts

There are six 3D printed parts in orange¹² that form corner connectors between the laser cut acrylic panels and one potentiometer knob. The connectors are based on Låda¹³ 3D printed parts.

These two parts space the PCB from the face acrylic panel on the lower edge and allow the front, sides and bottom acrylic panels to be attached:

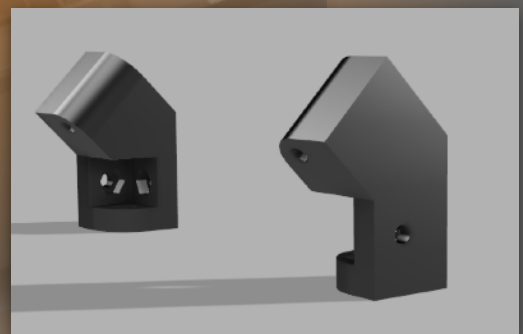

These two parts space the PCB from the face acrylic panel on the upper edge and allow the sides and back acrylic panels to be attached:

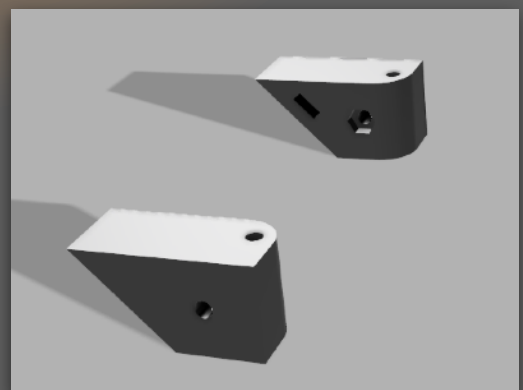

¹² Or any other colour of your choosing!

¹³ <http://wyolum.com/lada-a-custom-project-box-system/>

These parts allow the sides, back and bottom acrylic panels to be attached:

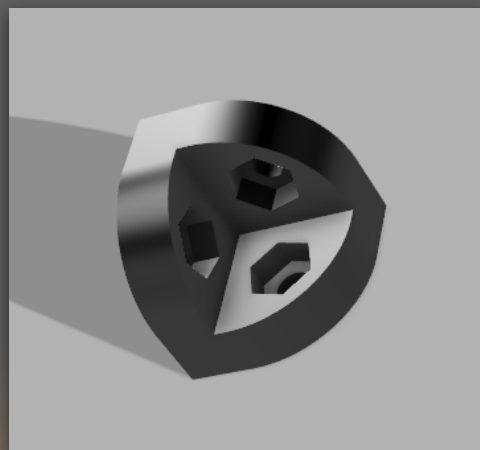

The potentiometer knob is 3D printed in orange¹⁴ as well:

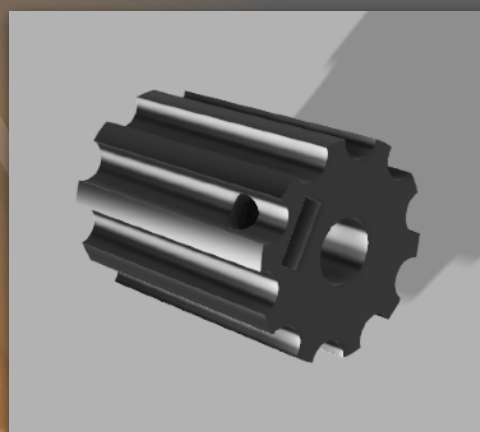

Case assembly

Case assembly is not difficult and the description that follows shows *one* method. If you are an experienced constructor then you will probably only need to glance through the next few pages and then build the case how you see fit.....

1. Completing the låda¹⁵ parts.

These six parts have hex recesses that will accept M3 nuts. The recesses are a very tight fit so the nuts become captive. The method I prefer is to use slip joint pliers¹⁶ (channel-locks) to squeeze the nut down into the recess. Moderate force is needed and the nut needs to be aligned above the recess or there is a risk that the components will be break. An alternative method is to position the nut above the recess and heat the nut gently with the tip of a soldering iron so the it melts the PLA¹⁷ polymer which has a melting point around 150 - 160 °C and can then be gently pushed down into the recess. A third way is to use a screw to tighten a nut into its recess and then back out the screw again. There are a total of 14 M3 nuts to position.



¹⁴ Again, if you're building your own case and have a 3D printer, feel free to *not* print it in orange....;-)

¹⁵ I have to admit to some disappointment when I discovered that låda means "box" in Swedish - I was hoping for something more *evocative*

¹⁶ Such as tongue-and-groove pliers also known as water pump pliers, adjustable pliers, groove-joint pliers, arc-joint pliers, multi-grips, tap or pipe spanners, gland pliers, *etc etc...*

¹⁷ https://en.wikipedia.org/wiki/Polylactic_acid

2. Preliminary wiring

Attach two lengths of wire to the screw terminals on the PCB. Use the provided wire divided into two roughly equal lengths.

3. Assemble the PCB to the face acrylic panel

Here's the assembly of the lower left and right front 3D printed parts, PCB and face acrylic panel. The components are assembled with two nylon M3 30mm bolts and nuts. Note that the curved edge faces into the PCB and the 3 hex nuts face inwards as well.

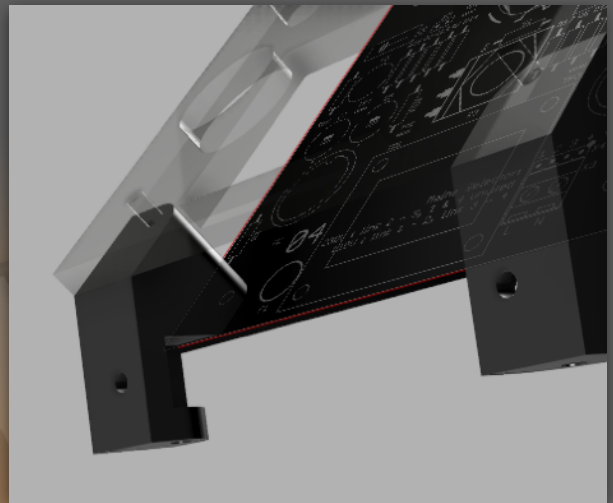

And here's the assembly of the top left and right 3D printed parts, PCB and face acrylic panel. The components are assembled with two nylon M3 30mm bolts and nuts. Note that the curved edge faces into the PCB and the hex nut and nut slot face inwards as well.



4. Add the rear acrylic panel

Attach the mains switch into its hole on the rear acrylic panel. Bolt the "figure of 8" connector using two M3 12mm (15mm) bolts, washers and nuts.

Drop a square M3 nut into one of the slots on the top 3D printed parts. Take care to keep it in the slot as it is intentionally loose. Attach the back acrylic panel using a M3 12mm (or 15mm for the thicker acrylic version) bolt but don't fully tighten the bolt. Swing the back acrylic panel so you can drop a second M3 square nut into the other slot. Swing the back acrylic panel back and use a second bolt to fix the back acrylic panel in place.

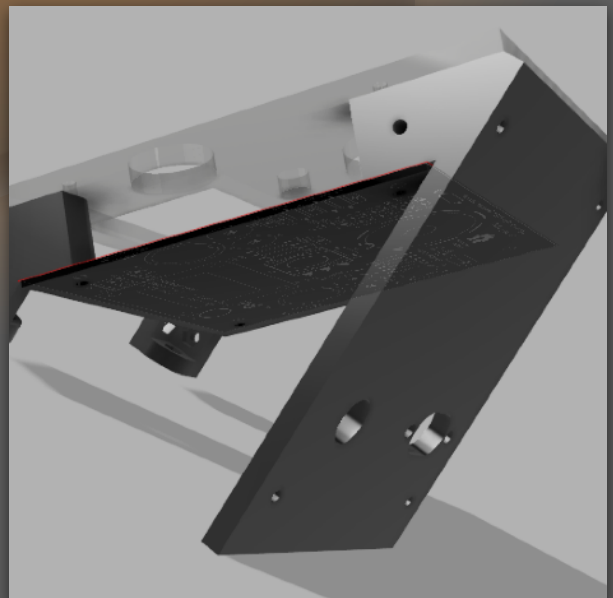

5. Complete the wiring

You can now solder on wire from the PCB to the “figure of 8” inlet. Use a length of shrink wrap tubing to cover the joint. Solder the other wire to the switch and then use an off cut to loop from the switch to the “figure of 8” inlet. Again, use shrink wrap tubing over each joint.

6. Add the front panel

Use two M3 12mm (15mm) bolts to attach the front acrylic panel:

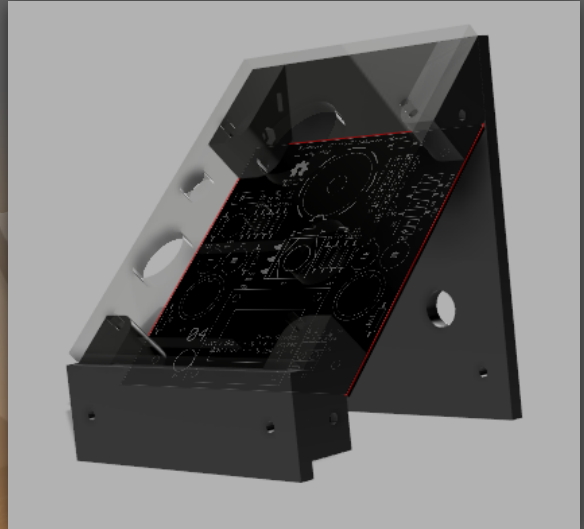

7. Add the side acrylic panels

Use two M3 12mm (15mm) bolts to attach the lower back 3D printed parts to the acrylic back panel:

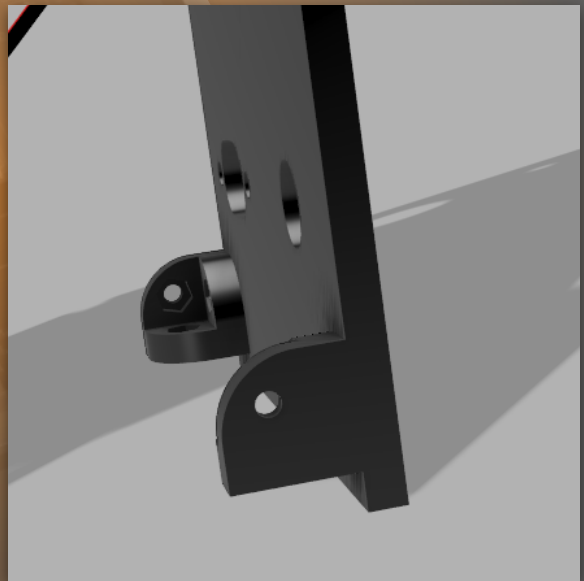

Use a M3 20mm (25mm) bolt to attached the acrylic side panel (left or right) to one of the top 3D printed parts and two M3 12mm (15mm) bolts to attach the acrylic side panel to the lower back and front 3D printed parts. Repeat for the other side:

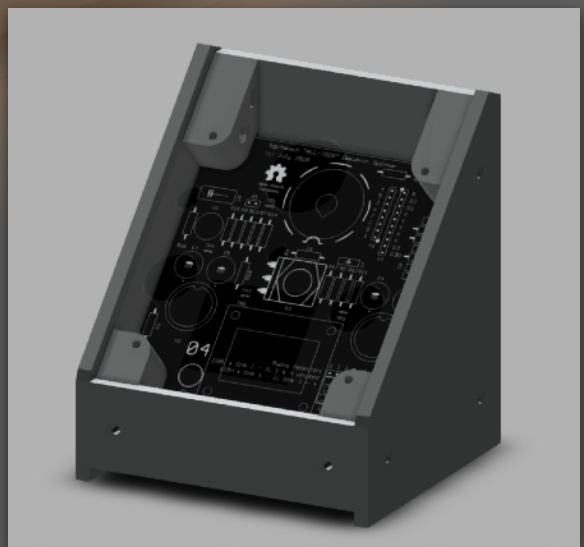

8. Add the under acrylic panel

Use four M3 12mm (15mm) bolts to attached the acrylic under panel:

9. Attached the potentiometer knob

Slide a M3 square nut into the slot in the potentiometer knob and screw in the 6mm grub screw so that it is engaged with the square nut but not so far that it protrudes into the shaft hole. The knob can be slipped over the potentiometer shaft and the grub screw tightened.

10. Case completed

Now plug the completed spinner into the mains and enjoy!

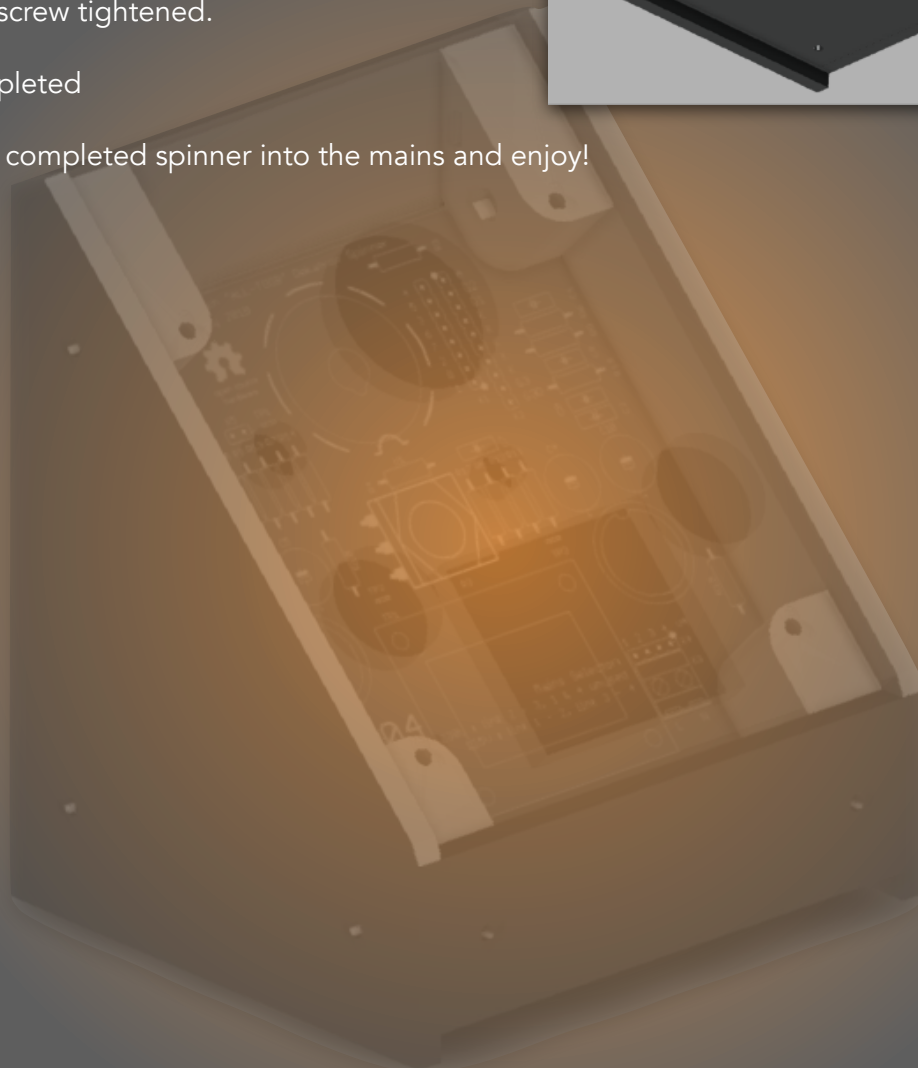
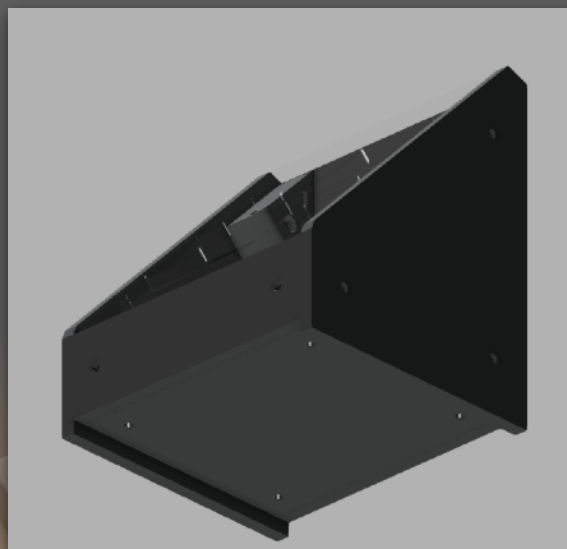

How It Works!

The schematic breaks down into 3 sections and are all discussed in turn below.

- Power supply unit
- Relaxation oscillator
- Dekatron pulse guide driver and Dekatron selection

Power Supply Unit

This must provide 270V DC for the trigger tube oscillator and 475V DC for the Dekatron anode.

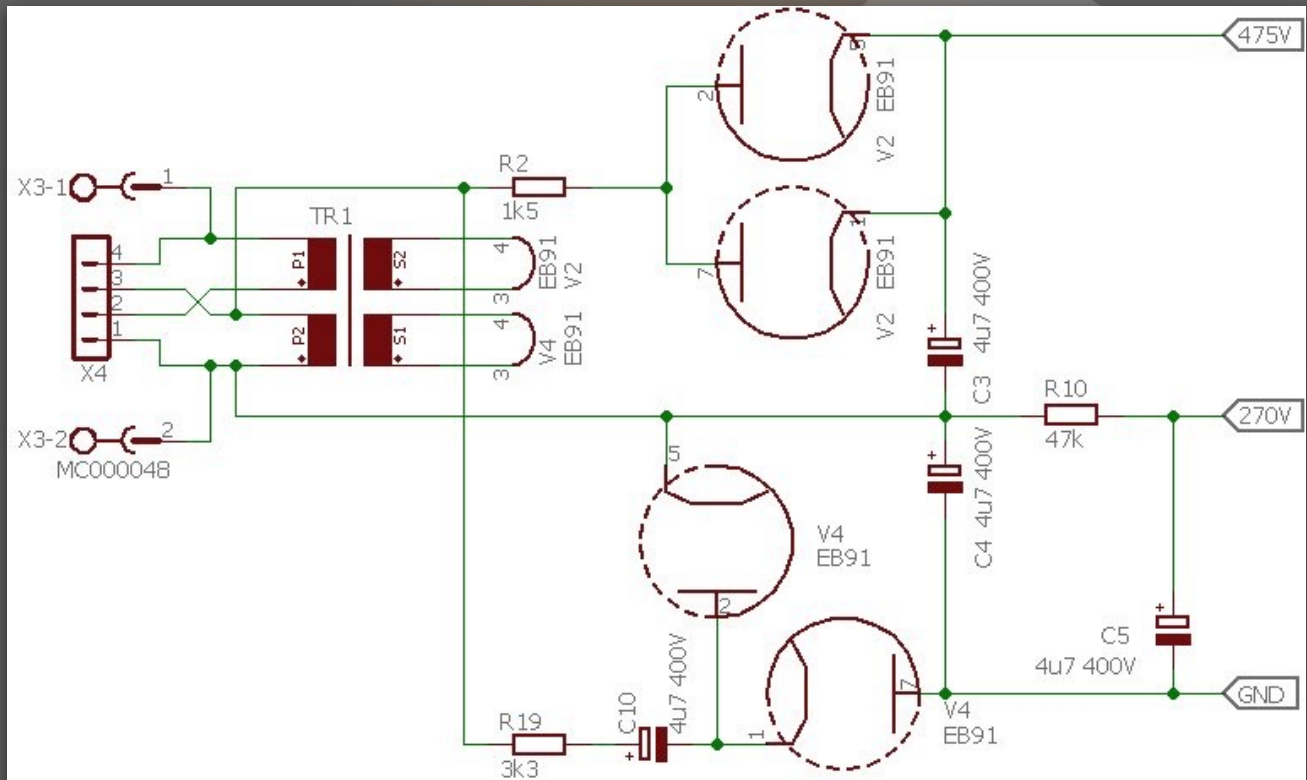

With 115V AC line/mains supply the two primaries of TR1 are in parallel. The transformer provides two isolated 6V AC supplies for the two rectifier valve heaters. The rectifiers are line/mains fed directly. V2¹⁸ is arranged as a half wave rectifier¹⁹ produces about 162V across C3. V4 is arranged as a voltage doubler²⁰ and produces about 325V across C4. These voltages are slightly lower due to voltage drop across R2 and R19. In practice about 475V is developed across C4 and C3 in series for the Dekatron anode supply. R10 drops the voltage across C4 down to about 270V for the trigger tube relaxation oscillator and Dekatron guide bias.

With 230V AC line/mains supply the two primaries of TR1 are in series. However, the centre point of the two transformer primaries is used to feed the two rectifiers. In this arrangement TR1 acts as an auto-transformer.²¹ Now fed with 115V AC the two rectifier valves operate as described above.

Safety First!

Note that whatever the operation, the line/mains supply is rectified directly and therefore there is no isolation and the "GND" line cannot be connected to line/mains ground/earth!

¹⁸ <http://www.r-type.org/exhib/aaa0010.htm> abused as a low current rectifier

¹⁹ <https://en.wikipedia.org/wiki/Rectifier>

²⁰ https://en.wikipedia.org/wiki/Voltage_doubler

²¹ <https://en.wikipedia.org/wiki/Autotransformer>

Relaxation Oscillator

The trigger tube trigger-cathode gap is used as a relaxation oscillator:

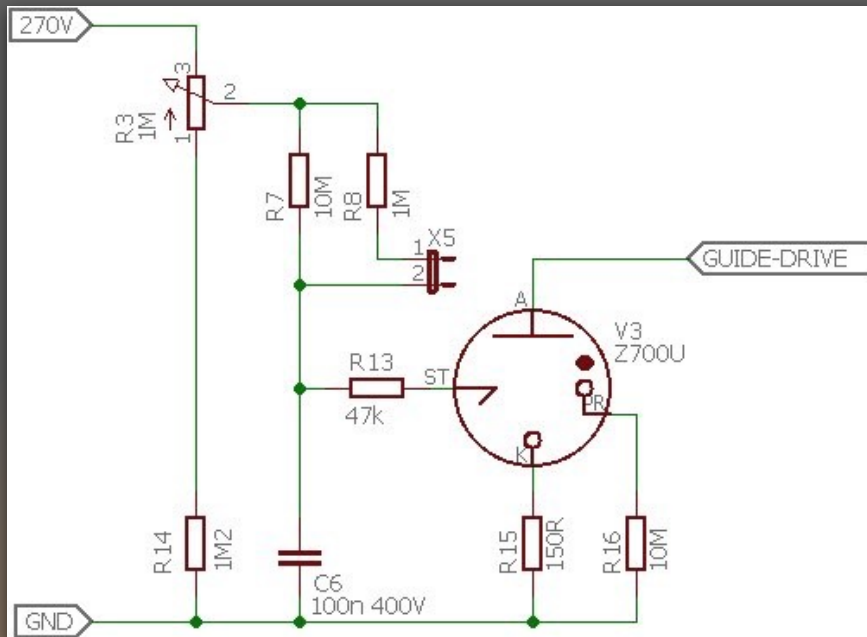

Capacitor C6 charges via R3 and R7 (and R8 in parallel if jumper X5 is fitted). When the trigger electrode-cathode gap trigger voltage is reached the gap ignites discharging C6 via R13. This is a classic neon lamp oscillator.²²

The function of R8 and X5 is to provide a reduction in the charging resistance path so the oscillator frequency is increased when X5 is fitted.

Safety

Under no circumstances should the jumper X5 be fitted or removed when the board is powered.

Potentiometer R3 provides a means to alter the oscillation frequency by a simple adjustment. The shaft of R3 **must be non-conductive e.g. plastic.**

Dekatron Guide Pulse Driver

When you come to the complete schematic at the end of this section you will see that driving the Dekatron guide electrodes is complicated by the different arrangements required by a single pulse Dekatron versus a double pulse Dekatron. The arrangement you choose depends on the type of Dekatron you are going to spin. Both arrangements used are described by JB Dance in "Electronic Counting Circuits" and there is an extract of the book at the end of this manual. The description that follows is a simplified version.

²² https://en.wikipedia.org/wiki/Pearson%E2%80%93Anson_effect

Arrangement for Single Pulse Dekatrons

This arrangement is used by Dekatrons such as the GC10D. This schematic shows a GC10D as an example:

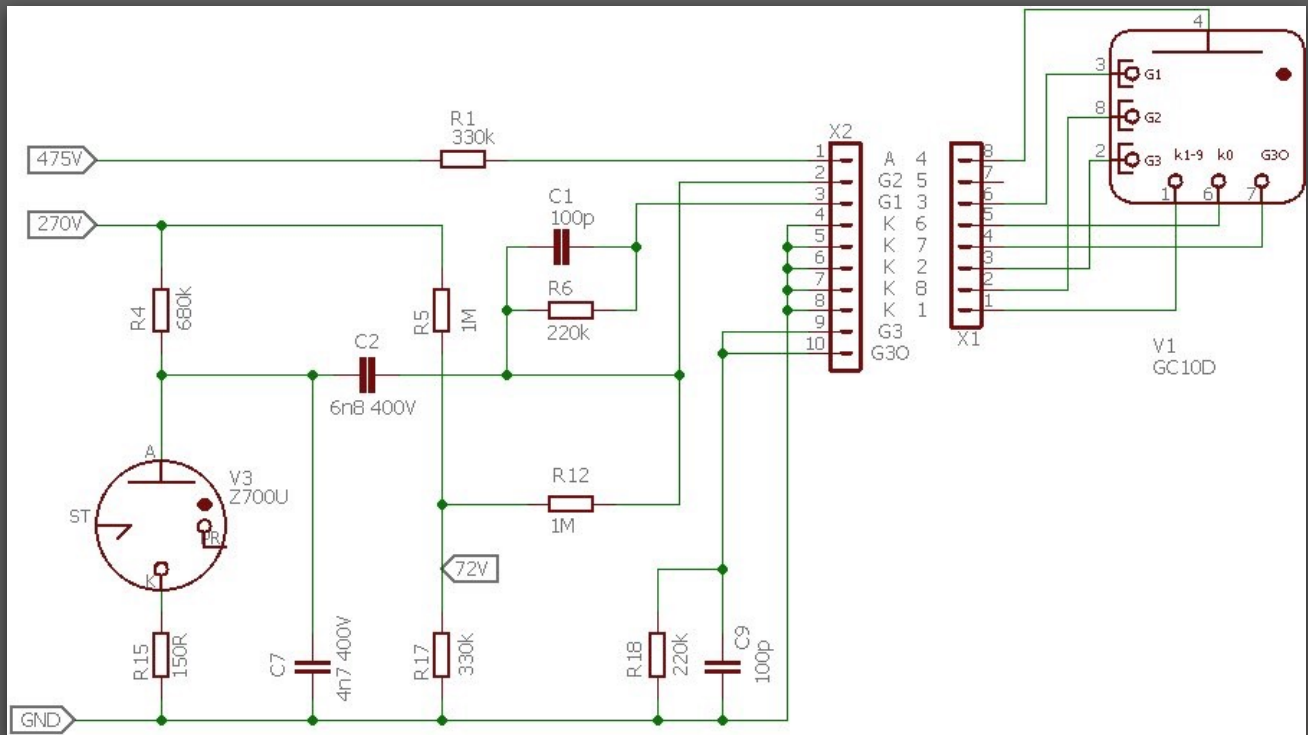

When the trigger tube V3 main anode-cathode gap is not conducting, C7 charges via R4. The final anode voltage of 270V is less than the voltage required for the anode-cathode gap to ignite until the trigger electrode-cathode ignites and then V3 conducts. C7 is rapidly discharged through V3 and R15. The voltage falls to below the maintaining voltage and the trigger tube self extinguishes. The cycle then repeats as the trigger electrode relaxation oscillator operates as previously described.

Each ignition of the trigger tube produces a negative going pulse which is taken forward by C2. When the pulse occurs, the discharge moves one position in a clockwise direction from the glowing main cathode to the adjacent first guide which has been strongly primed by R5, R12 and R17. The anode voltage falls so that the first guide to anode potential is equal to the maintaining voltage of the tube and the discharge to the main cathode is then extinguished.

The capacitor C1 in the first guide circuit charges from the current passing to the guide and the first guide potential increases. The discharge, therefore, transfers to the second guide which is still at its maximum negative potential.

During the remainder of the input pulse the discharge rests at the second guide, but when the pulse ceases the anode potential rises so that the anode to second guide voltage is kept at the maintaining voltage of the tube. The third guide then strikes, but soon the capacitor C9 in the third guide circuit becomes charged from the third guide current to a potential which is great enough to cause the discharge to transfer to the succeeding 'earthed' main cathode.²³

Finally, connectors X1 and X2 allow different Dekatron pinouts to be accommodated. This is fully described in the construction section *vida supra*.

²³ Simple huh?

Arrangement for Double Pulse Dekatrons

This arrangement is used by Dekatrons such as the GC10B (and variants), GC10/4B, GC12/4B and their CV equivalents. This schematic shows a GC10/4B as an example:

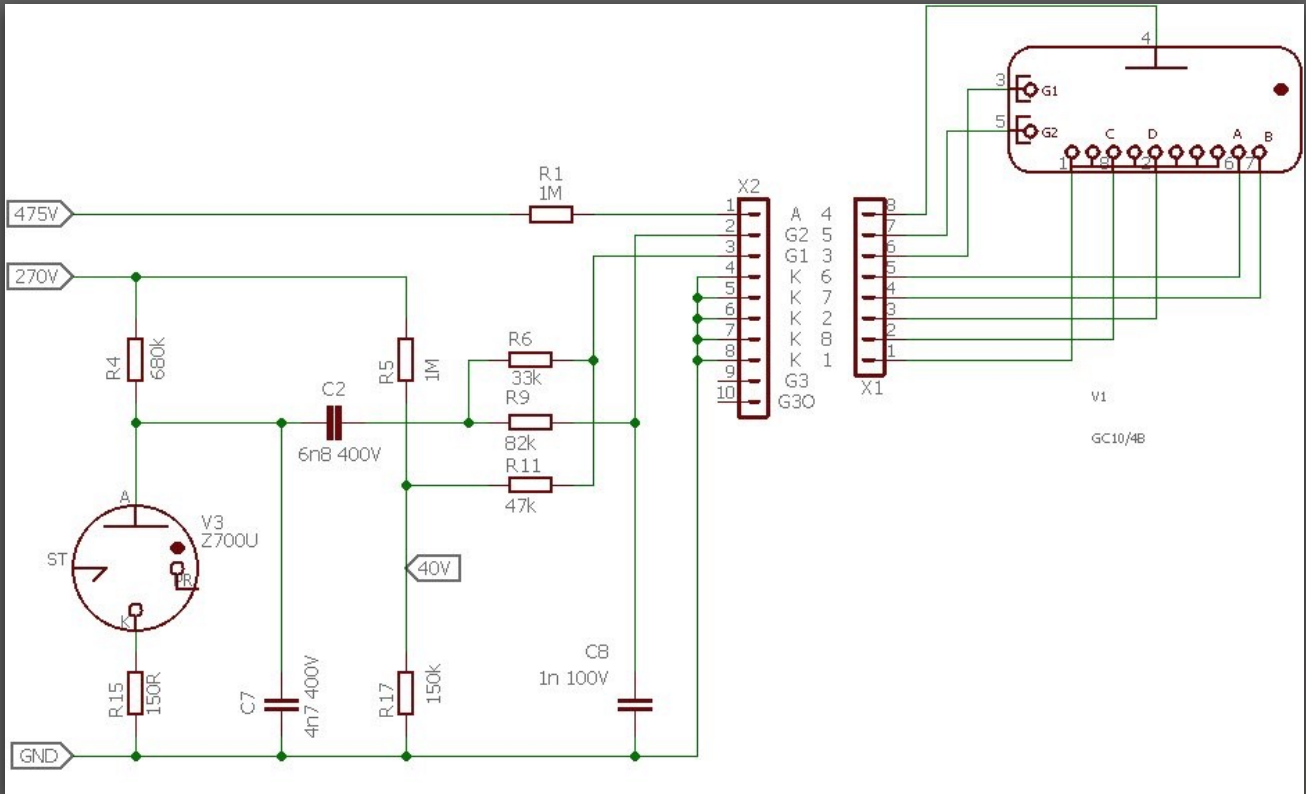

As above, when the trigger tube V3 main anode-cathode gap is not conducting, C7 charges via R4. The final anode voltage of 270V is less than the voltage required for the anode-cathode gap to ignite until the trigger electrode-cathode ignites and then V3 conducts. C7 is rapidly discharged through V3 and R15. The voltage falls below the maintaining voltage and the trigger tube self extinguishes. The cycle then repeats as the trigger electrode relaxation oscillator operates as previously described.

Each ignition of the trigger tube produces a negative going pulse which is taken by C2 and R6 to the Dekatron first guide electrode. R9 and C8 produce a delayed negative pulse for the second guide electrode. R5, R11 and R17 provide a positive guide voltage bias of about 40V.

The arrangement described advances the glow on the Dekatron in a clockwise direction. If the connections to the guide electrodes are swapped then the Dekatron glow will move in an anti-clockwise direction.

Finally connectors X1 and X2 allow different Dekatron pinouts to be accommodated. This is fully described in the construction section.

The All-Toob Dekatron spinner uses a Z700U trigger tube to drive the Dekatron employed. The use of this trigger tube is discussed by JB Dance and is illustrated driving a double pulse Dekatron. JB Dance also describes how to drive a single pulse Dekatron. Two sections of his book have been extracted and reproduced below (with some minor editing).

4.3.4 Trigger Tube Coupling Circuits

Trigger tube circuits have been designed which will couple two decade counting tubes, only one Z700U trigger tube being required in each coupling circuit for pulse shaping and amplification. The Z700U has been chosen because of its small size, low cost, low power consumption and short de-ionisation time which permits operation at frequencies up to 400 c/s. The tube feeding the coupling circuit can thus be used to count at up to its maximum speed of 4 kc/s.

4.3.5 40 c/s Coupling Circuit

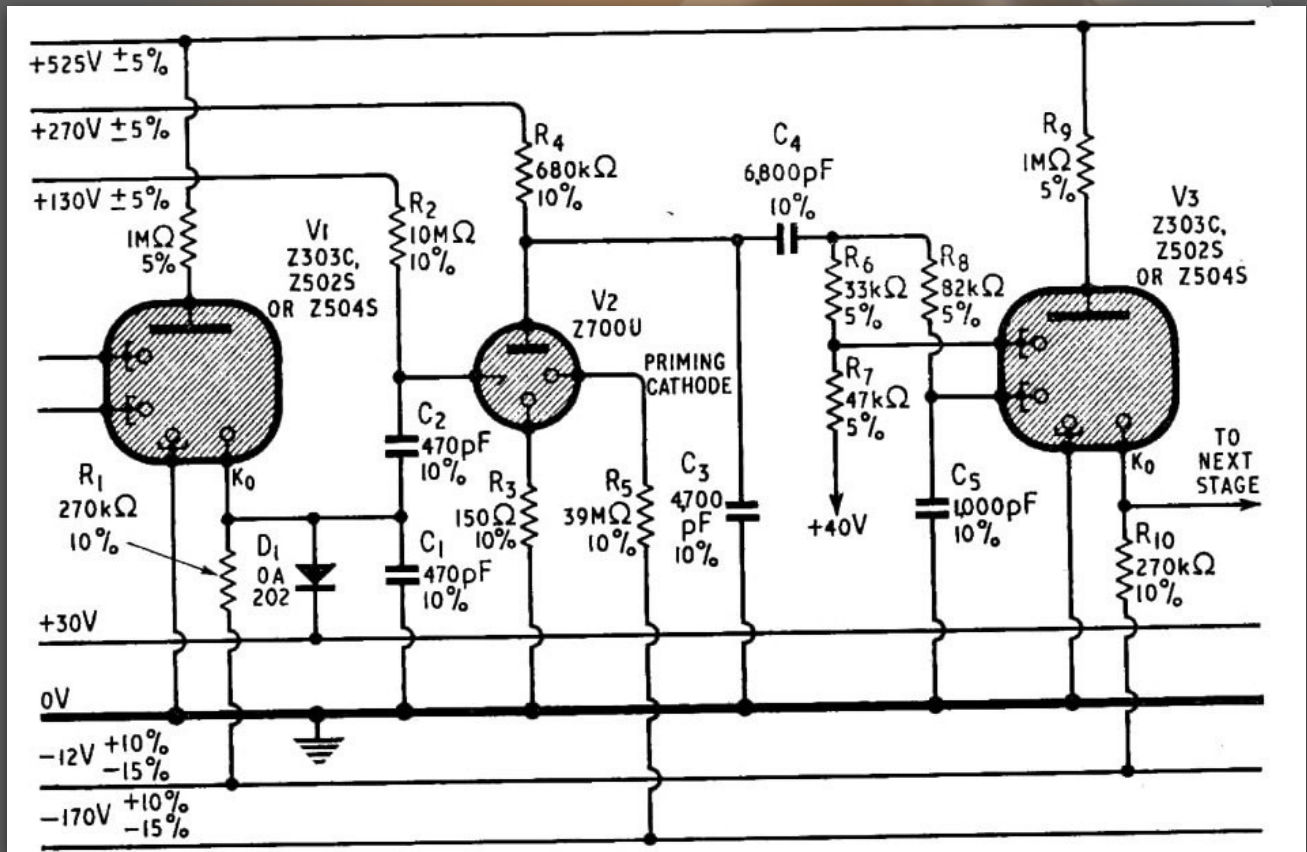

Figure 4.11 A 40 c/s trigger tube coupling circuit

The circuit for use at frequencies up to 40 c/s is shown in Fig. 4.11. The output pulse from V1 is fed via C2 to V2 which is ignited. The trigger of V2 also receives a positive bias from R2. The V2 circuit is self extinguishing owing to the presence of R4 and C3. The negative anode pulse from V2 is used to operate the succeeding counter tube.

The maximum voltage which should be present at the zero cathode of V1 is 30 V. If a simple cathode resistor were to be used to return the output cathode to the -12 V line, the output voltage would depend on the exact values of the components and of the supply voltage. This difficulty is prevented in the circuit of Fig. 4.11 by the use of a large Ka cathode resistor - which alone would provide a pulse exceeding a peak value of 30 V above earth - and by the use of a clamping diode from the Ko electrode to the +30 V line as shown. As soon as the output voltage tends to exceed

30 V above earth, the diode conducts and prevents any further rise in the output potential. The tolerance in the amplitude of the output voltage is thus determined by the tolerance in the potential of the 30 V line rather than by the wider variations in the counter tube current. No Z700U tube will ignite at a trigger voltage lower than +137 V, whilst all Z700U trigger tubes should ignite at trigger voltages of +153 V. A bias of 130 V \pm 5 % applied to the trigger electrode of V2 can be shown to ensure reliable operation with the component and supply voltage tolerances specified.

The time constant of the components C2R2 must ensure self extinction and allow full recovery in the time of 25 msec between pulses at the maximum operating frequency of 40 pulses per second. The capacitor C1 is necessary to prevent spurious ignition of V2 at the end of the pulse from V1. The manner in which these spurious pulses can arise in the absence of C1 can be explained as follows. When V2 is extinguished by the action of R4C3, the anode potential falls to about +60 V in 20 μ sec and drags the trigger voltage with it. A negative going pulse of about 110 V can thus appear at the trigger electrode. This pulse is coupled to the output cathode of V1 which falls from about +30 to about 60 V. After V2 has been extinguished the current passing to the zero main cathode of V1 raises the potential of this cathode to +30 V - which is a 90 V step. This causes the trigger of V2 to rise from +60 to +150 V, which is enough to cause some Z700U tubes to strike.

When C1 is incorporated in the circuit, it forms a potential divider in conjunction with C2. If these two capacitors are equal in value, only half of the negative going pulse is fed from the trigger electrode back to the zero cathode and the resulting positive going pulse is much reduced in amplitude.

R6 and R7 should be large so that a large portion of the output energy from the anode of V2 is not wasted in the charging of C4. On the other hand the total resistance of R6, R7 and R8 should not be greater than 200 k Ω or the effective guide bias may rise due to the flow of guide current in these resistors. This could reduce tube life.

4.4.13 The GC10D Single Pulse Dekatron

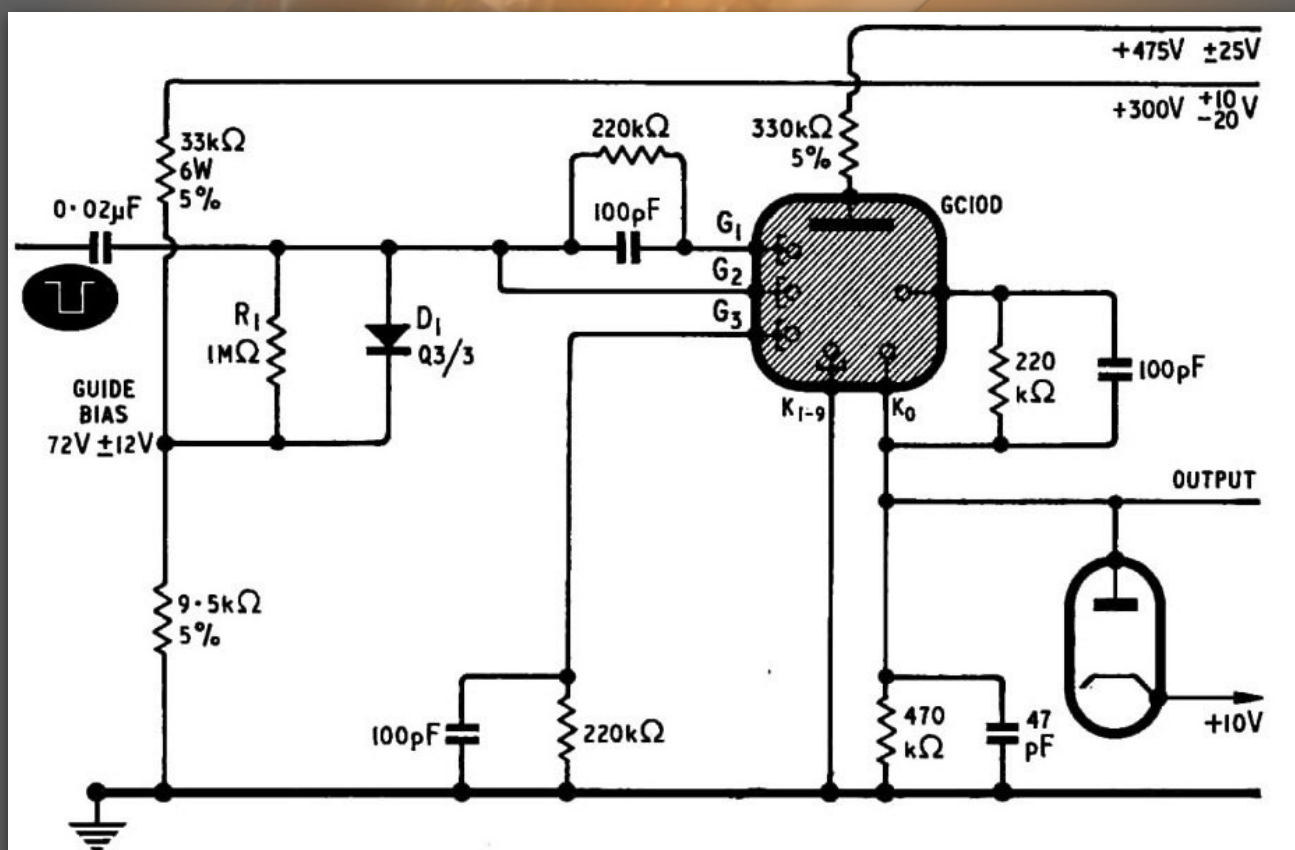

The GC1OD single pulse Dekatron requires only one input pulse to cause it to count. In addition it has the advantage that it can operate at frequencies up to 20 kc/s. The structure of the GC1OD tube is similar to that of the double pulse Dekatron, except that forty identical cathodes surround the common anode instead of the thirty cathodes used in double pulse tubes. Ten of the cathodes are main cathodes, whilst the remaining thirty are transfer or guide cathodes. There are three guide cathodes between each two main cathodes.

All of the guide cathodes which are on the clockwise side of the adjacent main cathode are joined together and are known as the first guides (G1 in Fig. 4.34). The electrodes on the clockwise side of each of the first guides are also joined together and are known as the second guides (G2). Nine of the third guides are joined together (G3), but the third guide preceding the output cathode is brought out to a separate base pin and is shown on the right hand side of the GC1OD circuit symbol in Fig. 4.34. It is known as the output third guide.

The basic type of circuit in which the GC1OD can be used for counting random pulses is shown in Fig. 4.34. The first and second guides are joined together via a resistor and a capacitor in parallel and are returned to a source of positive bias via a resistor R1 and a diode D1. The third guides are returned to earth via a parallel resistor and capacitor. The small capacitors in the guide circuits limit the rate of change of guide potential to a suitable maximum value.

The negative input pulses are applied directly to the second guides and also via the parallel resistor and capacitor to the first guides. When the pulse is applied, the discharge moves one position in a clockwise direction from the glowing main cathode to the adjacent first guide which has been strongly primed. The anode voltage falls so that the first guide to anode potential is equal to the maintaining voltage of the tube and the discharge to the main cathode is then extinguished.

The capacitor in the first guide circuit charges from the current passing to the guide and the first guide potential increases. The discharge, therefore, transfers to the second guide which is still at its maximum negative potential. Transfer will occur when the potential across the capacitor in the first guide circuit is equal to the difference between the primed striking voltage and the maintaining voltage of the tube.

During the remainder of the input pulse the discharge rests at the second guide, but when the pulse ceases the anode potential rises so that the anode to second guide voltage is kept at the maintaining voltage of the tube. The third guide which is strongly primed then strikes, but soon the capacitor in the third guide circuit becomes charged from the third guide current to a potential which is great enough to cause the discharge to transfer to the succeeding earthed main cathode.

Although each count requires four separate steps (as compared with the three steps of the double pulse Dekatrons), the time the discharge remains at the first and third guides is extremely short owing to the automatic transfer mechanism as the capacitors in the guide circuits charge. The length of time for which the discharge rests at the second guide electrode is determined by the length of the input pulse. Thus the four stepping operations which take place in a single pulse Dekatron can be arranged to occur in a shorter time than the three steps of the double pulse tube.

The diode D1 presents a large impedance to the input pulses and serves to prevent the first and second guide electrodes from becoming appreciably more positive than the guide bias supply point. If the diode were omitted, the ions from the adjacent conducting main cathode would produce a small current in R1 which would result in an additional positive bias being formed at the guides.

The third guide preceding the output cathode is connected to the latter by a resistor and capacitor in parallel. When the output cathode is conducting and is at a positive potential (owing to the flow

of current through the cathode resistor), the potential of the third guide is raised to the potential of the output cathode. The discharge is thus prevented from returning from the output cathode to the preceding third guide when the output cathode potential becomes positive with respect to earth.

The output cathode should not be allowed to rise to a potential above +10 V or the discharge may transfer spontaneously from this cathode to another electrode. A clamping diode is, therefore, used from the output to a 10 V supply as shown in Fig. 4.34. The amplitude of the input pulses to the second guides of the tube should be between 133 and 195 V and their duration should not be less than 25 μ sec.

